



 **BUNGE**

Energy and CO2 strategies in Bunge

ISCN-GULF Conference. EPFL Lausanne, 11 June 2009

Our Integrated Operations Circle the Globe, Stretching from Farm to Table

The world is our market. Bunge's over 25,000 employees in over 30 countries are dedicated to improving the global agribusiness and food production chain by:

- Manufacturing fertilizer and animal feed for farmers.
- Originating oilseeds and grains from the world's primary growing regions and transporting them to customers worldwide.
- Crushing oilseeds to make meal for the livestock industry and oil for the food processing, food service and biofuel industries.
- Producing bottled oils, mayonnaise, margarines and other food products for consumers.
- Milling wheat and corn for food processors, bakeries, brewers and other commercial customers.

Sustainability Policy

Bunge is committed to sustainable development and will adhere to the following principles:

- 1** We will **strive to be good citizens** by contributing to the economic and social development of the communities where we work;
- 2** We will **work to achieve a high level of environmental performance** by adopting science-based, culturally sensitive and pragmatic best practices and by promoting these practices within our supply chain;
- 3** We will **partner with companies and organizations** to promote and apply sustainable practices; and
- 4** We will **communicate openly about our activities** and have a constructive dialogue with stakeholders.

We will apply these principles across our operations,
pursuing both global and regional goals.

Looking Ahead

Bunge first global sustainability program focuses on four areas:



Climate

- Achieve low emissions with high cost-efficiency.
- Develop energy-savings goals.
- Pursue business opportunities in the carbon credit and emissions mitigation markets and other market-based solutions to climate change.



Waste Reduction

- Continue to establish processes that reduce key industrial and process wastes and water usage.
- Improve environmental management at our facilities.



Sustainable Agriculture

- Continue to increase the sustainability of the global agribusiness and food production chain.
- Take a leadership role in promoting sustainable, profitable practices among farmers worldwide.



Healthy Diets

- Expand Bunge's portfolio of food products that offer consumers added health benefits.
- Identify emerging dietary trends in order to create products that meet consumers' changing needs.

Environmental Performance Snapshot

- **Bunge Citizenship** presents our environmental performance using measures that we believe are relevant to our business and our stakeholders.
- It lists Bunge's global carbon footprint, energy and water consumption, and the amount of waste by disposal method.
- Our goal is to increase the breadth and depth of our environmental reporting over time.



Bunge Citizenship uses the GHG (greenhouse gas) Protocol developed by the World Business Council on Sustainable Development and World Resources Institute and select indicators based on the Global Reporting Initiative's G3 Reporting Framework.

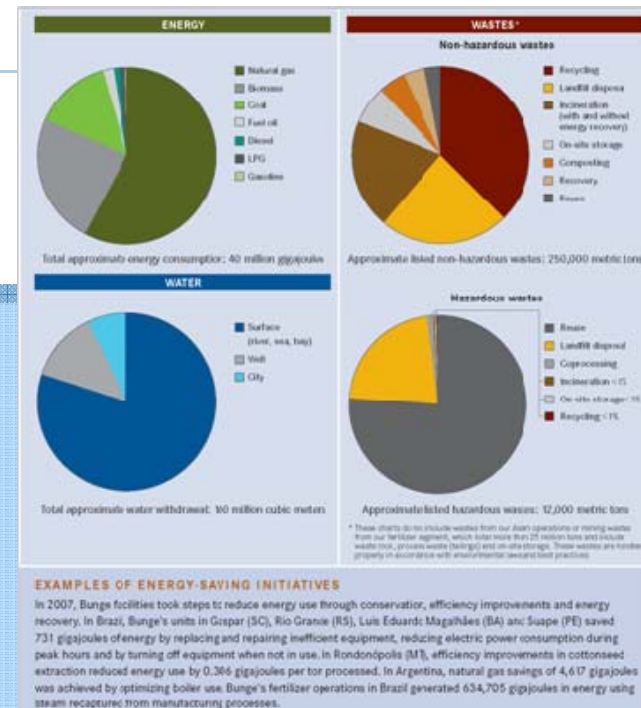

Bunge's Fuel Usage Distribution

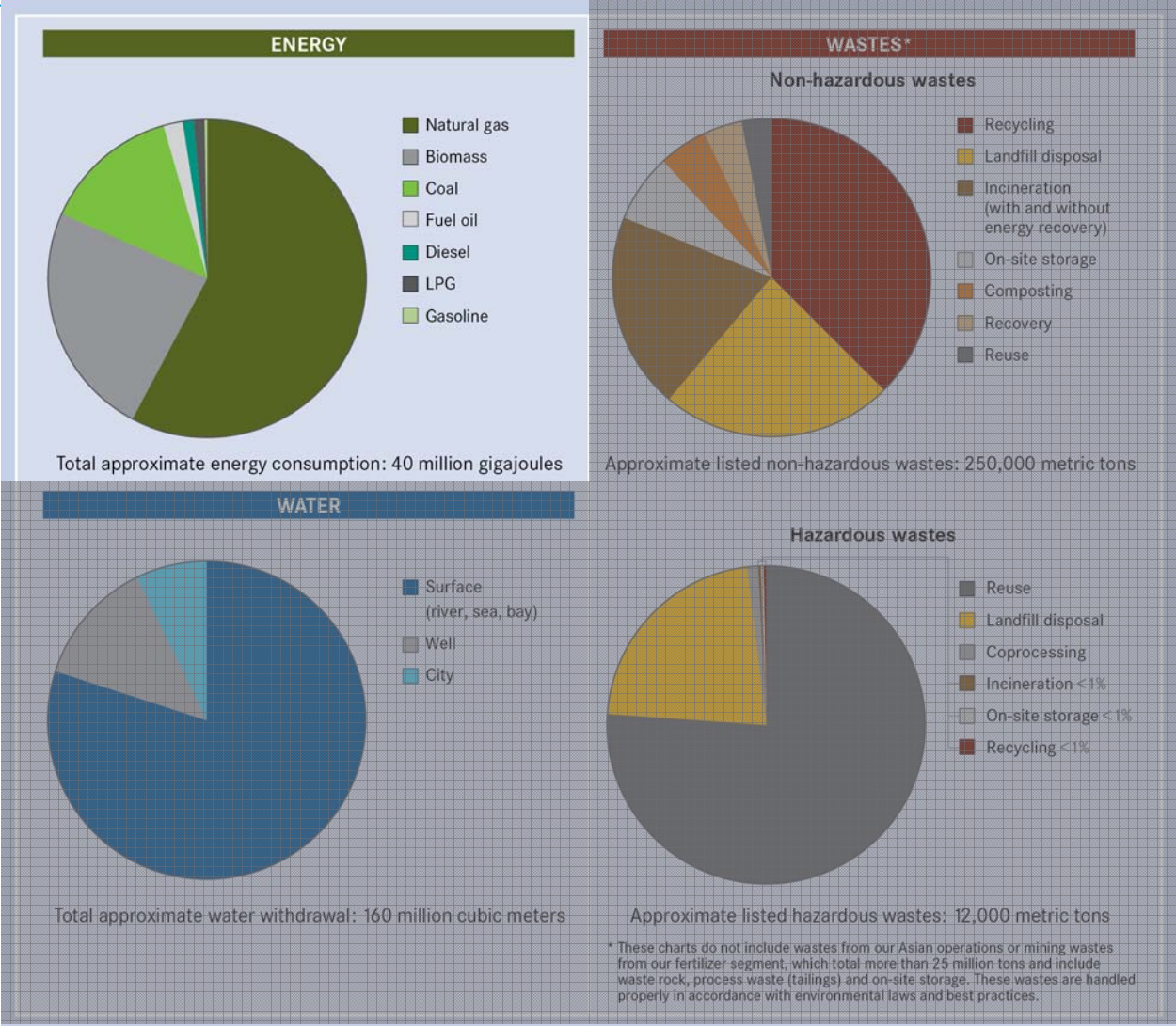

Bunge's Carbon Footprint

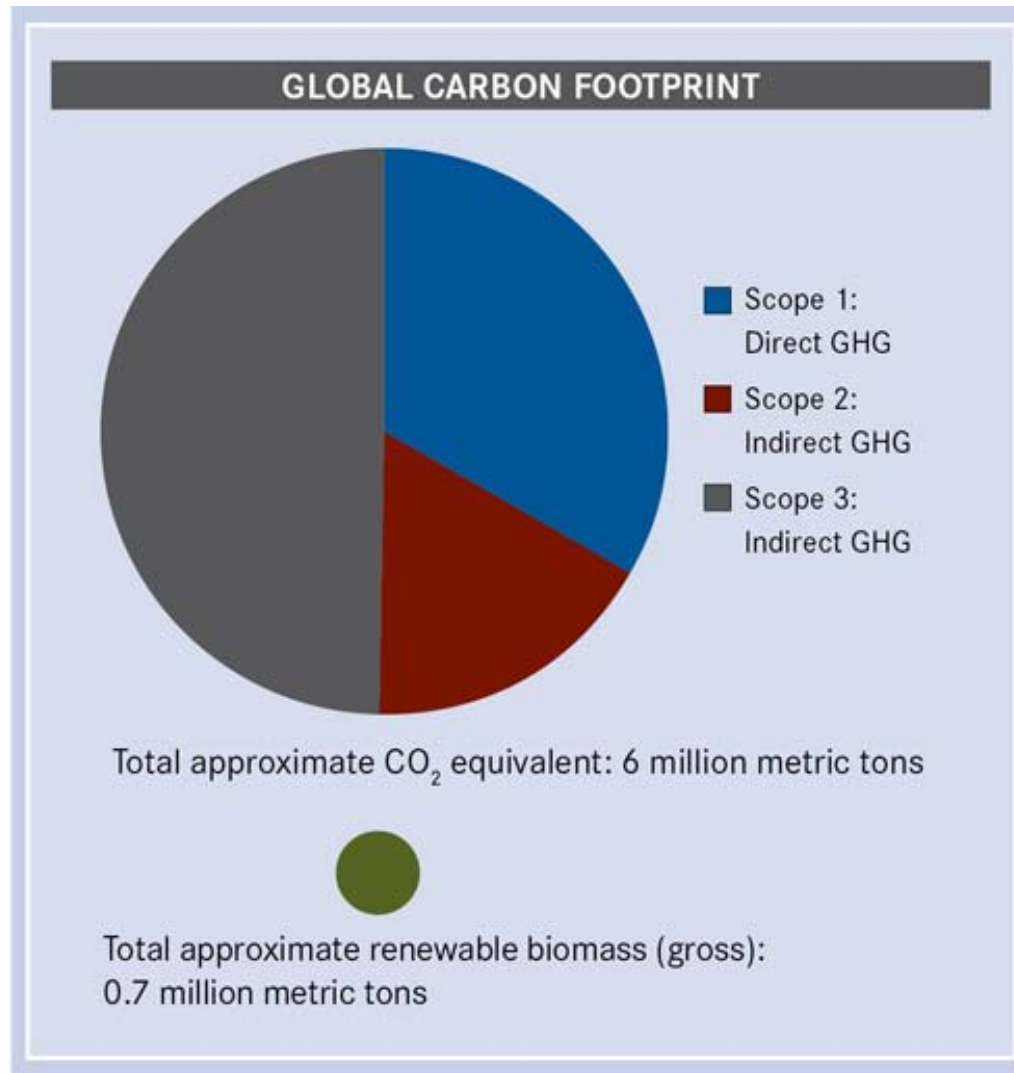

Scope 1 = Direct GHGs from Facilities.

Scope 2 = Indirect GHGs Associated with Electricity Used at Facilities.

Scope 3 = Indirect GHGs Associated With Ocean Freight.

Local Action Lines in Energy and CO2 reduction

- Energetic Efficiency Projects = Cost Savings
- Use of Best Available Technologies
- Biomass
- Use of Renewable Energies

Efficiency Projects

Identify & Pursue Opportunities

- Kaizen/Lean Sigma
- Capex Projects with low payback

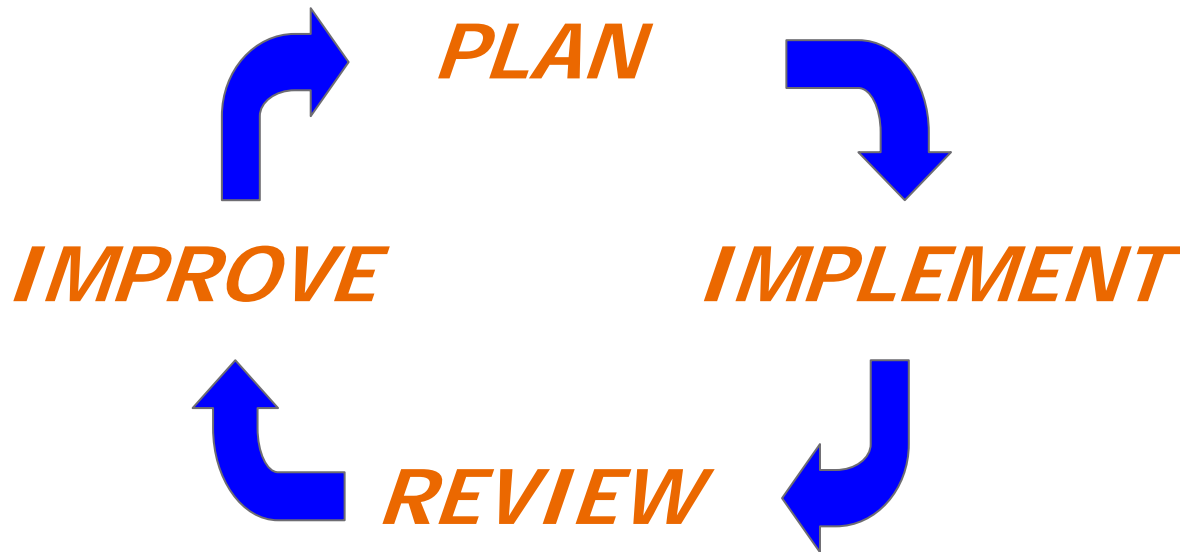

Biomass Strategy

ANNUAL ENERGY NEEDS OF THE PLANT OPERATION *

HEAT 290 GWh

POWER 70 GWh

TOTAL 360 GWh

ANNUAL ENERGY CONTENT OF THE SEPARATED SF HULL **

< 513 GWh

- THE SF HULL IS NOT WASTE BUT CHEAP ENERGY SOURCE THAT CAN COVER THE TOTAL ENERGY DEMAND OF THE PLANT
- TRANSPORTATION OF HULL IS NOT ECONOMICAL DUE TO IT'S LOW DENSITY (0.2 T/M3)
- INCREASE DENSITY BY PELLETIZING IS EXPENSIVE (VARIABLE C. AND MAINTENANCE)
- THE CO2 EMISION OF HULL BURNING IS NOT CONSIDERED IN CO2 CREDIT ASPECT

THE MAIN QUESTIONS ARE :

➤ **HOW CAN WE BETTER CONVERT HULL ENERGY INTO HEAT AND POWER ?**

AND AS THE EFFICIENCY OF HEAT CONVERSION IS MUCH HIGHER THAN POWER CONVERSION

➤ **HOW COULD WE REPLACE A PART OF POWER NEEDS WITH HEAT?**

* PROCESSED SF SEED 750 KT/Y, REFINED OIL 300 KT/Y, BOTTLED OIL 250KT/Y

** CALORIC VALUE OF THE 112 KT/Y SEPARATED HULL

Biomass Strategy

- Hulls Boilers

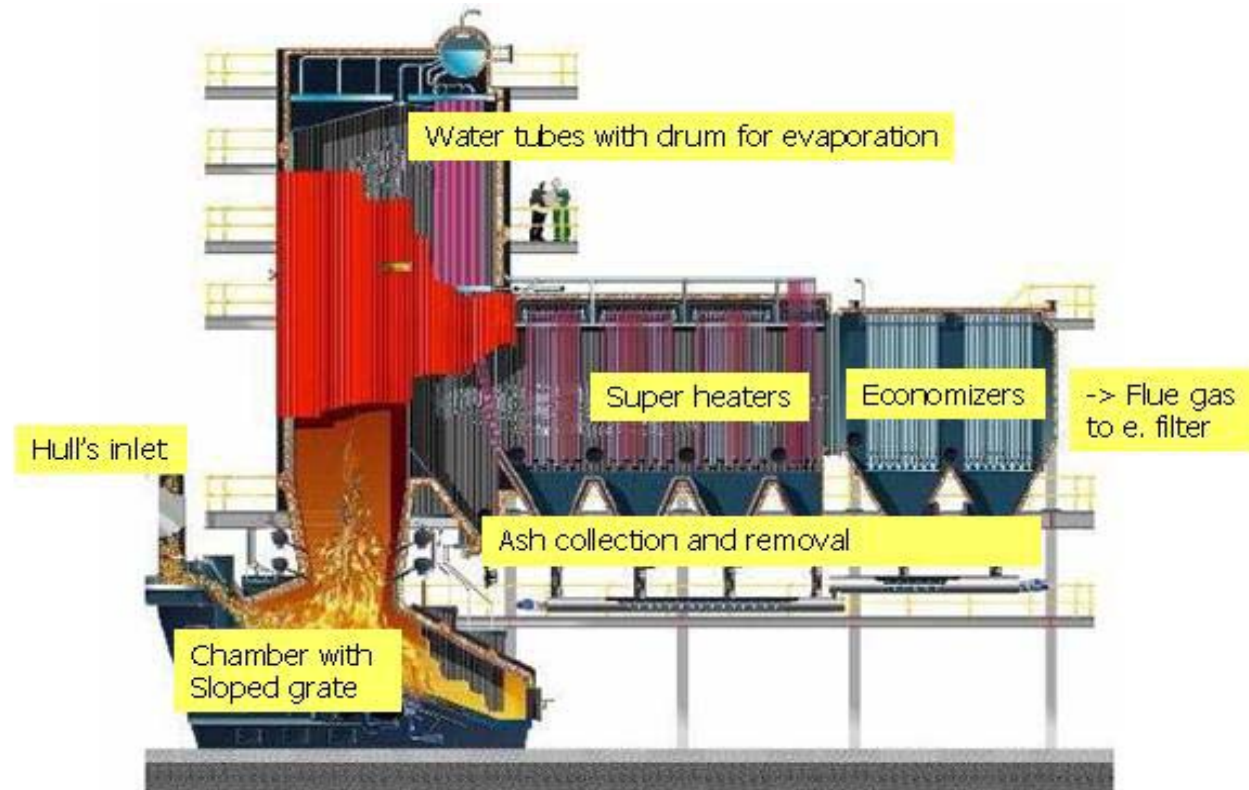

Best Available Technologies

- Absorption Cooling Compressors



Best Available Technologies

- Condensation Type Turbine

Estimated Steam Turbine Performance

Project Number 085.0101.0A0
 Project Name Dalkia
 Date 22.02.2007
 Model TBM-TV3-MARC4CX
 Case Design

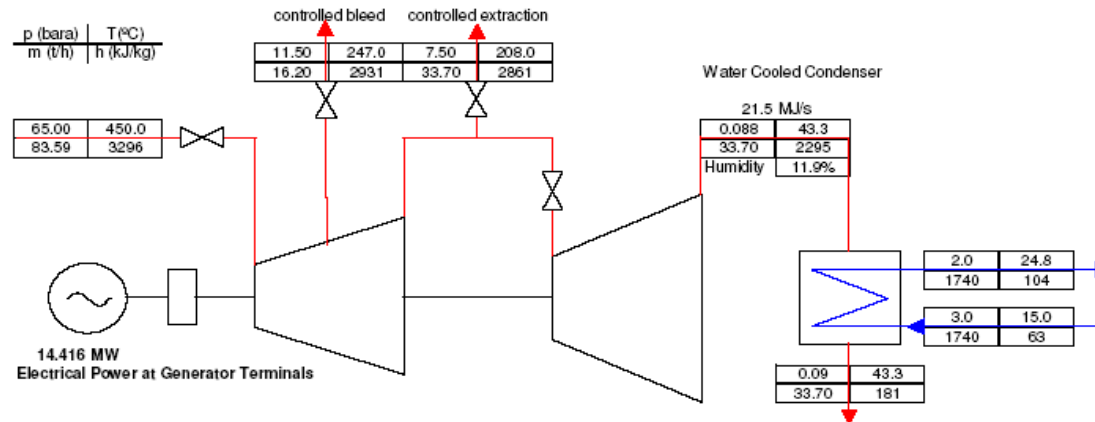

Cogeneration

- Gas or Vegetable Oil

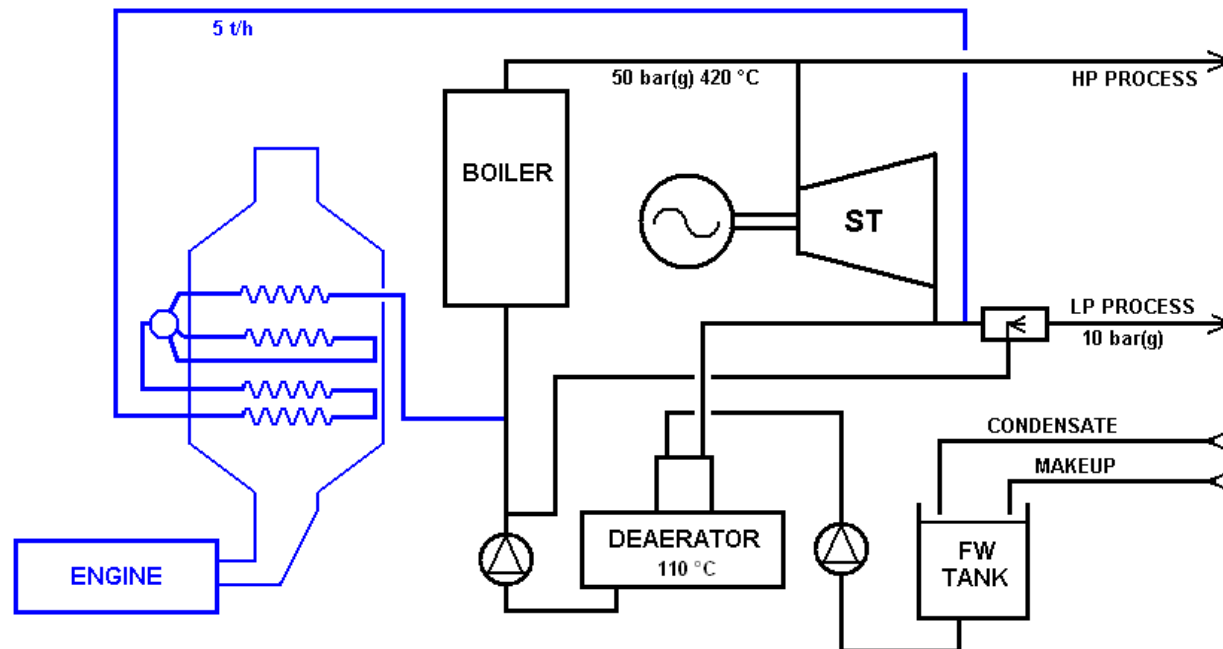

Citizenship Starts With Our Purpose

Bunge is committed to being a good corporate citizen.

- Acting ethically.
- Ensuring highest levels of safety.
- Conducting business in a manner that promotes environmental quality.
- Increasing agricultural production in a sustainable way.
- Helping employees achieve their full potential.
- Furthering the well-being of the communities where we operate.



Our purpose is to enhance lives by improving the global agribusiness and food production chain.

Thank you!
